

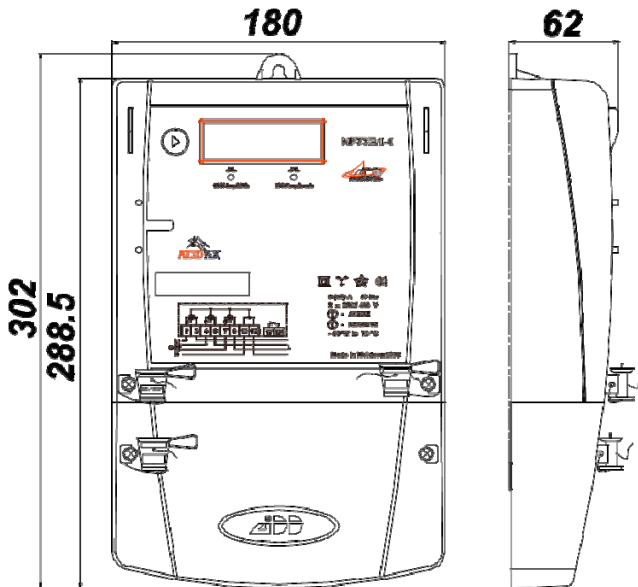

NP73E.1-x-x

MULTI-FUNCTION
AND MULTI-TARIFF
THREE-PHASE
ELECTRONIC
METERS
DESIGNED FOR USE
IN AMI/AMR
SYSTEM

OVERALL DIMENSIONS (mm)



METER CONNECTION DIAGRAM
(IEC)

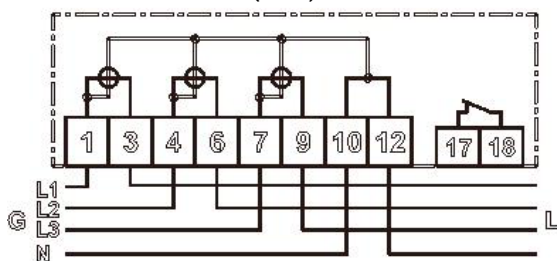

Three-phase meters
Based on up-to-date
ADDAX Technology
For residential metering

KWh	Kvarh	Active energy, reactive energy in two directions
V	A	Measured quantities
T1-T6		Multirate registration
		Built-in clock
		Event Log
		Load profile
I1≠I2		Differential current detection
IP54		Protection level
		Reserve power supply
IEC		Standard data model, open protocols
		Optical port
		Basic and extra relay
		Sensor of meter case opening
		Sensor of terminal box cover opening
		Magnetic field sensor
		Sealed reset button (optional)
DIN		DIN rail mounting (optional)
PLC		Built-in PLC module
M-Bus	CM-Bus	M-Bus/CM-Bus connector (optional)
		Keypad/control joystick (optional)

- ▶ AMR with integrated PLC communication
- ▶ Indication of operational status and alarming
- ▶ High EMC immunity
- ▶ Fraud and theft protection
- ▶ Load control with internal relay
- ▶ Remote software upgrade
- ▶ Optical port for local meter reading/parametrization/upgrading

FUNCTIONS

DLMS/COSEM SUPPORT

- Standard data model
- Standard communication protocols
- Interoperability

BUILT-IN CLOCK

- Real Time Clock (RTC)
- RTC accuracy 0,5 s. (IEC 62052-21)
- External synchronization
- Sleep mode, supercapacitor or battery
- Automatic change-over for daylight saving time

MEASURED QUANTITIES

- Active energy, accuracy class 1.0
- Reactive energy, accuracy class 1.0, 4 quadrants
- Energy export and import
- Power, Max Demand (demand interval 15, 30, 60 min, day, month)
- Voltage, instantaneous value, RMS
- Phase current, neutral current, difference between phase and neutral currents

METERING DATA

- Actual meter readings
- Periodic (daily, monthly) meter readings
- Interval (15', 30', 60') meter readings
- Timestamp

DATA STORAGE

- Non-volatile memory (10 years)
- Capacity depends on data type and number and can be expanded for one type of data on the expense of another
- Up to 4 types of interval profiles. For example:
 - Monthly data – 8 registers, each of 15 records
 - Daily data – 8 registers, each of 90 records
 - Hourly data – 4 registers, each of 360 records
 - 15 minutes data – 2 registers, each of 1440 records

BUILT-IN DISPLAY

- LCD, 8 digits, configurable decimal place
- Special symbols, data identification according to IEC 62056-61 (OBIS)
- Metering data and specified messages displaying
- Dynamical screen changeover
- Display self-testing
- Backlight
- Sleep mode

MULTI-RATE METERING

- Up to 6 tariff registers
- Up to 8 changeovers per day
- Tariff indicator is transmitted on display and to an external system
- Remote (via PLC) and local change of tariff plan

CALENDAR

- 2 seasons per year
- Up to 3 daily profiles per week
- Up to 30 special days per year

PREPAYMENT MODE

- Optional, depending on meter model
- Both credit and prepayment mode support
- Possibility to change mode during meter's operation
- Prepayment mode in compliance with Standard Transfer Specification (STS)
- Keypad for tokens input
- Token input by PL and optical channel

EVENTS & ALARMS PROCESSING

- Current state of meter's functional nodes and parameters and alarm events. Timestamps
- Standard set of events including: registration in the special logs and registers, event report sending, displaying, load switching off on special cases

LOAD CONTROL

- Built-in relay 100 A
- Control modes:
 - remote,
 - local by condition,
 - manual (by push button)
- Relay status displaying

POWER LOAD CONTROL

- Optional, depending on meter model
- Built-in relay 5 A, which controls external powerful contactor
- Control modes:
 - remote,
 - scheduled local
- Relay status displaying

ELECTRICAL ENERGY QUALITY CONTROL

- Quality indexes:
 - Average Voltage
 - Voltage Sags
 - Voltage Swells
 - Outages
 - Network Frequency
 - Angles between phases
- Special counters and logs to store data received
- Remote or local parametrization of parameters' limits

FRAUD & THEFT PROTECTION

- Continuous monitoring, including sleep mode time
- Fraud types under control:
 - Meter case opening
 - Terminal box opening
 - Inadmissible differential current
 - Reverse meter connection
 - Strong external magnetic field (more than 200 mT)
- Protective seals

METER SELF-CONTROL

- Built-in test for nonrecurrent and continuous self-control
- Results registering
- Quick response on severe error

TEST OUTPUTS

- Outputs: LED, Optical ports
- Parameters under control: active energy, reactive energy, time

DATA TRANSMISSION

- Data transmission on demand
- Request types:
 - Concentrator request (via LV PLC)
 - HHU request (via optical port)

POWER LINE COMMUNICATION (PLC)

- Built-in SoM2a-module
- S-FSK/OFDM modulation
- CENELEC, A Band
- EMC standards compliance
- Auto-discovery
- Repeating (up to 7 levels)

OPTICAL PORT

- IEC 62065-21
- Data transmission rate 9600 bps
- Possibility of local data exchange and data parametrization

AUXILIARY COMMUNICATION CONNECTOR

- Optional, depending on meter model
- M-Bus/CM-Bus connector within the terminal box

CONTROL ELEMENTS

- Optional, depending on meter model
- 12-digits keypad for tokens input in prepayment mode
- Joystick for listing meter readings and connection/reconnection the meter
- Reset button to reset the meter readings to zero. Can be sealed to secure authorized access

CUSTOMER DEVICES SUPPORT

- Metering data acquisition (1 hour/24 hours)
- Status control (once per hour)
- Event processing
- Device control

METER PARAMETRIZATION

- Remote (via PLC) or local (via optical port)
- Access right
- Events registering

SOFTWARE UPGRADE

- Remote or local software upgrade

INFORMATION SECURITY

- Communication encryption protection
- Data access according to access rights stated
- Events registering
- Antinoise coding
- Firmware protection

RESERVE POWER SUPPLY

- Optional, depending on meter model
- Supercapacitor, ensures meter's backup power supply in sleep mode up to 72 hours
- Battery, ensures meter's backup power supply in sleep mode. Battery lifetime – up to 20 years

TECHNICAL SPECIFICATIONS

Accuracy class: - Active energy (IEC 62052-11, IEC 62053-21) - Reactive energy	1 1
Reference current, I _b	2,5÷20 A <i>depending on meter model</i>
Maximum current, I _{max}	100 A
Minimum current	0.05 I _b
Starting current: - Active energy - Reactive energy	0.004 I _b 0.005 I _b
Reference voltage, U _n	3×230/3×120 V <i>depending on meter model</i>
Voltage range	0.8 U _n ... 1.2 U _n
Reference frequency	50 Hz
Meter constant: - Active energy - Reactive energy	1000/2000 imp/kWh 1000/2000 imp/kvarh <i>depending on meter model</i>
Extended temperature range (IEC 60721-3-3)	-40°C ... +70°C
Storage temperature (IEC 60721-3-3)	-40°C ... +70°C
Internal clock	quartz crystal 32 kHz
Clock accuracy (at 25°C) (IEC 62052-21)	≤0.5 s /24 h
Data transmission rate via PLC, up to	2400 bps (S-FSK, IEC 61334-5-1) 128 kbps (OFDM PRIME)
Inherent consumption of current circuit, not more	1 VA
Inherent consumption of voltage circuit active/total, not more	2 W / 10 VA
Insulation strength (IEC 61010-1-90)	4 kV, 50 Hz, 1 min
Shock voltage (IEC 60060-1)	12 kV, 1.2/50 μs
Electrostatic discharge (IEC 1000-4-2)	15 kV
High frequency radiant field (IEC 1000-4-3)	10 V/m
High frequency interferences (IEC 1000-4-4)	4 kV
Connection type	Direct connection
IP rating	IP54
Dimensions	302 x 180 x 62 mm
Mass, not more than	2 kg

HOUSING

- Light-tone non-flammable polycarbonate
- IP 54 protection against water and dust

TERMINALS OF CURRENT CIRCUITS

- Universal clamping type: D = 8.5 mm